

**Valve/Cavity Compatibility**

For additional information see Technical Tips on pages BC1-BC2.

		VALVE				
		Winner's Circle	Parker	Waterman	FPS	CEC
CAVITY	Winner's Circle	X	X	X		
	Parker	X	X	X		
	Waterman	X	X	X		
	FPS					
	CEC					X

**Performance Curve**  
**Pressure Drop vs. Flow**

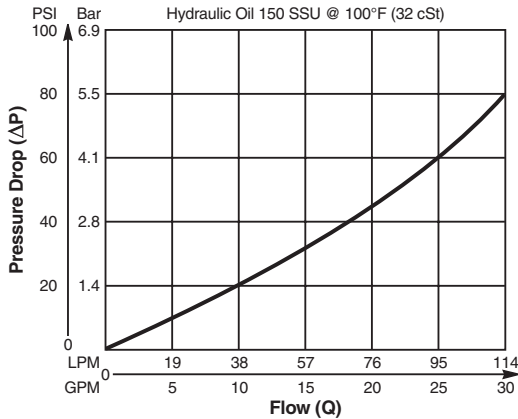

**Dimensions** Millimeters (Inches)

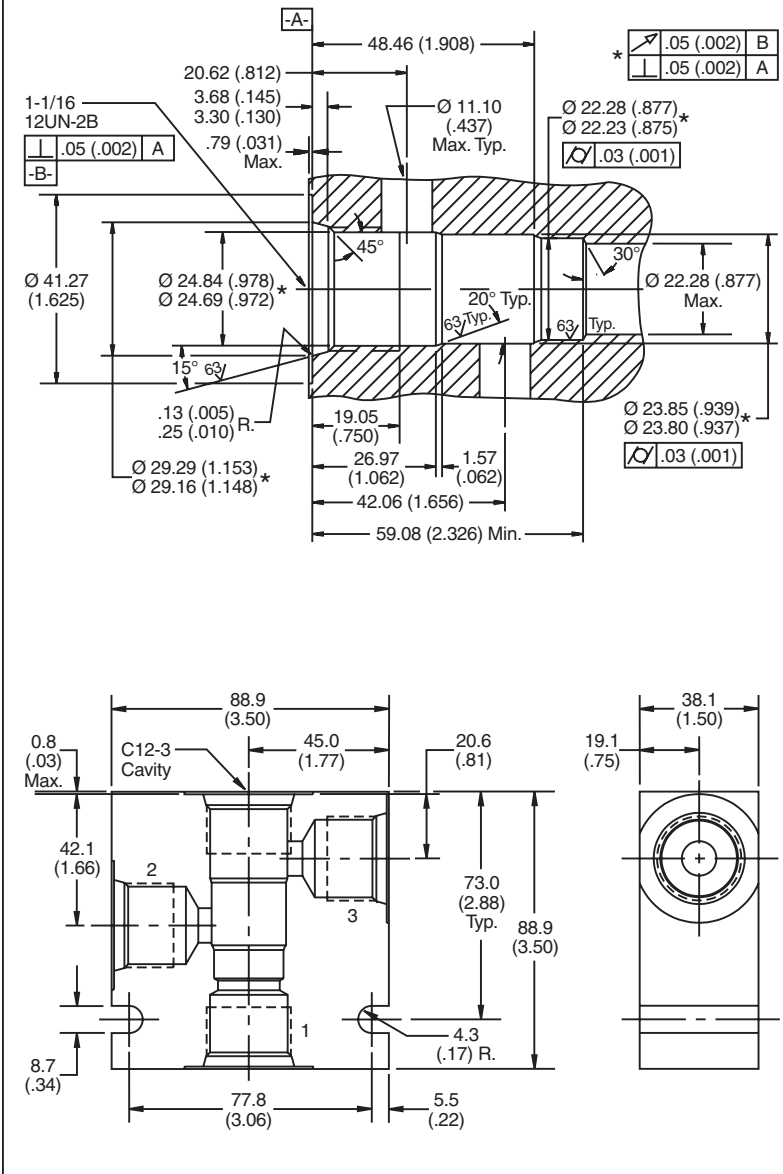

**Ordering Information**

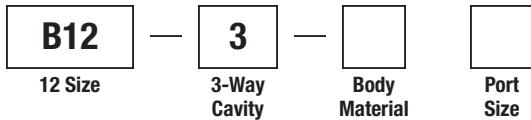

Code	Body Material
Omit	Steel
A	Aluminum

Code	Port Size
12T	SAE - 12

**Form Tool:** Rougher NFT12-3R  
 Finisher NFT12-3F  
**Weight:** 2.0 kg (4.5 lbs.)

- CV
- Check Valves
- SH
- Shuttle Valves
- LM
- Load/Motor Controls
- FC
- Flow Controls
- PC
- Pressure Controls
- LE
- Logic Elements
- DC
- Directional Controls
- MV
- Manual Valves
- SV
- Solenoid Valves
- PV
- Proportional Valves
- CE
- Coils & Electronics
- CB
- Carpak Bodies
- BC
- Bodies & Cavities
- TD
- Technical Data